

EXD

Automatic Pressure Differential Switchover

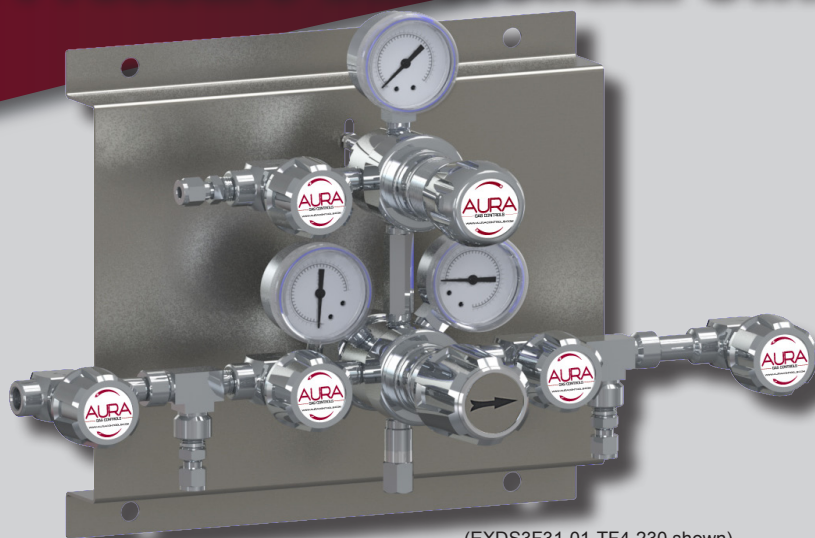

(EXDS3F31-01-TF4-230 shown)

The AURA EXD is an automatic switchover system designed to provide a continuous supply of high purity gas for inlet pressures up to 4500 psig. The integral EX1 line regulator provides consistent outlet pressures. AURA's encapsulated seat design consolidates the numerous moving internal components of a standard regulator into one single piece, allowing for ease of maintenance and minimizing potential failure points. Protected by a 10-micron 360° filter, the encapsulated seat provides significantly more filtration of impurities than the standard pressed-in disk. The encapsulated seat also filters damaging particles from all inlet ports rather than just the pipeline port.

AURA's proprietary machining process yields surface finishes of 4-25 Ra designed to reduce corrosion. The optional inlet purge or shutoff valve assemblies require minimal connections, reducing potential leak paths and internal volume. With its minimal internal volume, the EXD allows less gas to be used while purging. The EXD's regulators are assembled in a Class 100 clean room while the complete EXD assembly is 100% helium leak checked and cleaned for oxygen service. Additionally, the EXD undergoes multiple flow and function tests to meet the harsh demands and rugged environments of any application worldwide. The AURA EXD allows for maximum flexibility and superior functionality as the engineer's first choice for an uninterrupted supply of high purity gases.

EXD Features

Differential pressure switching technology

- Fail safe operation

Line and switching regulator encapsulated seat design

- Ease of maintenance

Fully configurable inlets, outlets, and purges

- Flexible application specific solution

Dual surface diaphragm

- Increased precision even at lower pressures

4", 12", or 24" panel

- Easy integration into existing system



(EXDS7F00-01-000-000 shown)



EXD Automatic Differential Switchover

Technical Data and Product Specifications

Materials of Construction

	EXDS	EXDB
Body	316L stainless steel	Chrome-plated brass
Bonnet	304 stainless steel	Chrome-plated brass
Diaphragm	316L stainless steel	316L stainless steel
Seat	PCTFE (manifold regulator) PTFE (line regulator)	PCTFE (manifold regulator) PTFE (line regulator)
10-micron 360° filter	316L stainless steel	Copper nickel
Nozzle	316L stainless steel	Chrome-plated brass
Purge/Diaphragm valves	316L stainless steel	Chrome-plated brass

Functional Specifications

Design Pressure	<ul style="list-style-type: none"> Working pressure: 4500 PSIG PCTFE Burst pressure: > 4x Working pressure 	Temperature	• -40°F to 140°F (-40°C to 60°C)
Maximum Inlet Pressure	• PCTFE (4500 psig maximum inlet pressure)	Weight	<ul style="list-style-type: none"> • 24" panel appx. 19 lbs. (8.62 kg.) • 12" panel appx. 15 lbs. (6.80 kg.) • 4" panel appx. 13 lbs. (5.90 kg.)
Leak Rate	<ul style="list-style-type: none"> • External: 1×10^{-8} He ccs • Seat: 1×10^{-7} He ccs 		

Principles of Operation

Automatic differential pressure switchovers provide an uninterrupted and reliable supply of high purity gases. The proven switching technology enables fail-safe operation utilizing a priority valve assembly. While the inlet pressure to the switchover begins to drop as the primary cylinder is depleted, the priority valve switches to draw gas from the reserve cylinder now making it the primary cylinder. This allows the end user to replace the empty cylinder (or cylinder bank) without interruption and increases system efficiency as cylinders need to be changed less frequently.

Essential to the function of critical applications and analytical systems, a continuous gas supply ensures reliability in processes as downtime is eliminated, cycle times are shortened, and results are more consistent. With AURA's proprietary switching technology, the EXD offers the highest available flow rates without drawing gas from both cylinders. This feature eliminates depletion of the reserve cylinder as system demand increases and stabilizes delivery with reliable upstream pressure. The EXD also maximizes cylinder economy so more gas can safely be drawn from each cylinder before change-out is needed. The EXD's fully configurable inlets provide flexibility to properly fit application-specific requirements for fittings, purges, and isolation valves.

Each EXD Switchover assembly includes:

- Regulators cleanroom assembled
- 100% helium leak check
- Cleaning for oxygen service
- 100% function test
- Silicone-free assembly
- Certificate of conformance
- Certificate of cleaning for oxygen

EXD Typical Installation

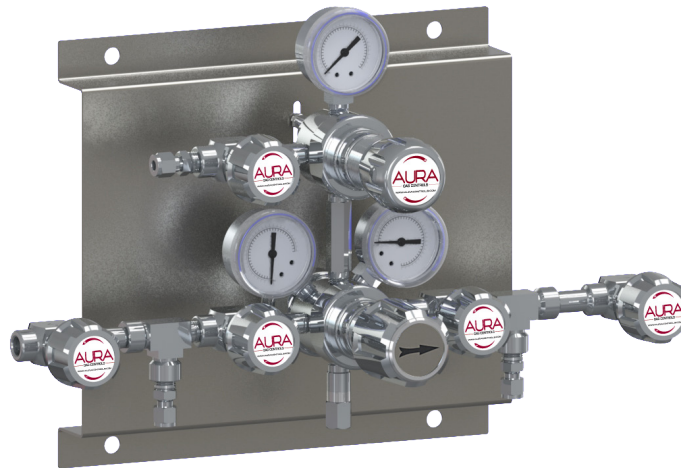

(EXDS3F21-01-TF4-230 shown)

Ordering Information

EXD 4 5 6 7 8 **-01-** 13 14 15 **-** 16 17 **0**

Digit 4 - Material of Construction

- S = Stainless steel
- C = Chrome-plated brass

Digit 5 - Pressure Range

- 1 = 0-15 psig
- 2 = 0-50 psig
- 3 = 0-100 psig
- 4 = 0-200 psig
- 5 = 0-350 psig
- 7 = 0-150 psig

Digit 6 - Gauges (Major/Minor Scale)

- 0 = None
- 1 = Inlet (psig/kPa)
- 2 = Outlet (psig/kPa)
- 3 = Both inlet and outlet (psig/kPa)
- 5 = Inlet (BAR/psig)
- 6 = Outlet (BAR/psig)
- 7 = Both inlet and outlet (BAR/psig)
- E = Inlet pressure switch gauge (BAR/psig)
- F = Inlet pressure switch gauge and outlet gauge (BAR/psig)

Digit 7 - Inlet Assembly

(See back page for assembly details)

- 0 = None
- 1 = Diaphragm Valve
- 2 = Direct purge
- 3 = Tee Purge

Digit 8 - Panel Option

- 0 = 4" Wide panel
- 1 = 12" Wide panel
- 2 = 24" Wide panel

Digits 13-15 - Inlet Connection

- 000 = None (1/4" female NPT)
- M06 = 6mm ss compression tube fitting
- M08 = 8mm ss compression tube fitting
- M10 = 10mm ss compression tube fitting
- M12 = 12mm ss compression tube fitting
- TF2 = 1/8" ss compression tube fitting
- TF4 = 1/4" ss compression tube fitting
- TF6 = 3/8" ss compression tube fitting
- TF8 = 1/2" ss compression tube fitting

Digit 16 - Outlet Assembly

- 0 = No Valve, LH Outlet
- 1 = No Valve, RH Outlet
- 2 = Diaphragm Valve, LH Outlet
- 3 = Diaphragm Valve, RH Outlet

Digit 17 - Outlet Connection

- 0 = None (1/4" female NPT)
- 1 = 1/4" male NPT Fitting
- 2 = 1/8" ss compression tube fitting
- 3 = 1/4" ss compression tube fitting
- 4 = 3/8" ss compression tube fitting
- 5 = 1/2" ss compression tube fitting
- 6 = 6mm ss compression tube fitting
- 7 = 8mm ss compression tube fitting
- 8 = 10mm ss compression tube fitting
- 9 = 12mm ss compression tube fitting

Accessories:

- 36" 316L stainless steel hose with check valve and cylinder connection, 3000 psig EXPH0001-01-CON-000
- 36" 316L stainless steel hose with check valve and brass cylinder connection, 3000 psig EXPH0002-01-CON-000
- 36" 316L Monel®-lined hose with cylinder connection for oxygen service, 3850 psig EXPH0008-01-540-000

Key:

- ss = Stainless steel
- RH = Right hand
- LH = Left hand
- CON = Cylinder Connection

NOTE: If you are unable to find a configuration specific to your application's needs, call AURA Gas Controls directly at 800.582.2565.



1501 Harpers Road, Virginia Beach, Virginia 23454

800.582.2565

www.AURACONTROLS.com

Registered ISO 9001



EXD Automatic Differential Switchover Mounting and Installation Information

EXD Direct Purge Option

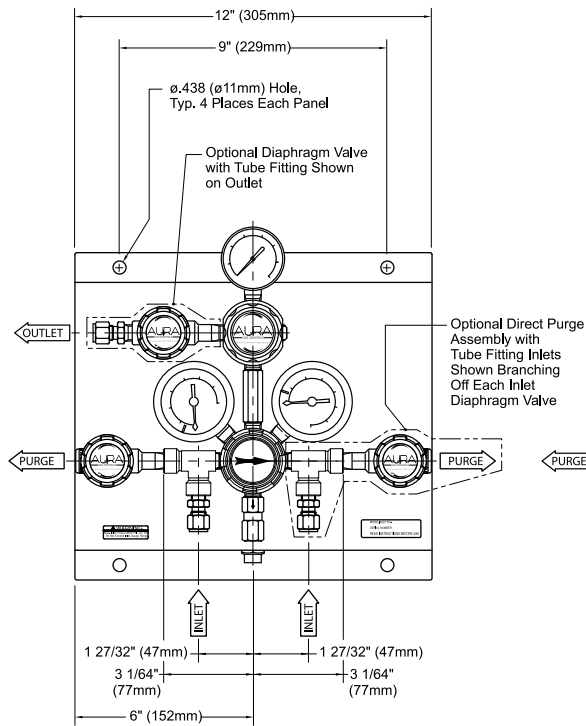

(EXDS3F21-01-TF4-230 shown)

EXD Tee-Purge Option

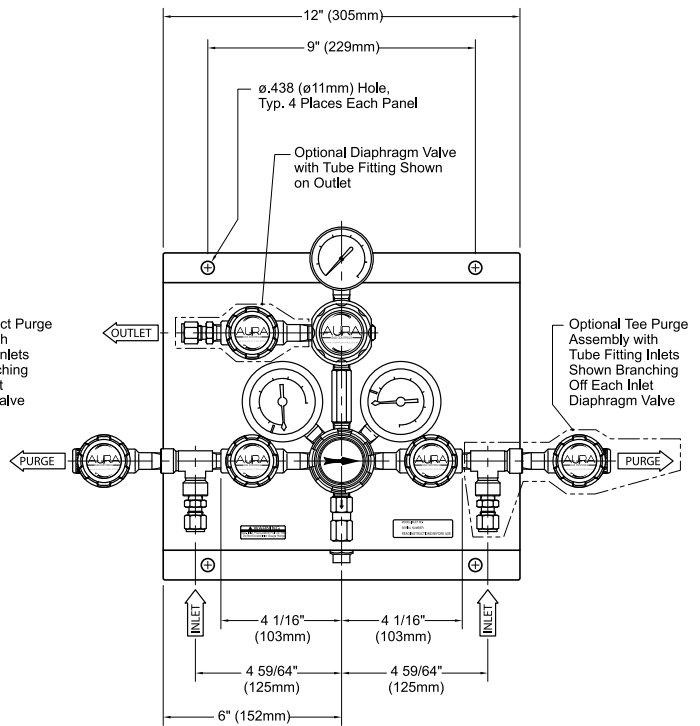

(EXDS3F31-01-TF4-230 shown)

EXD No Purge Option

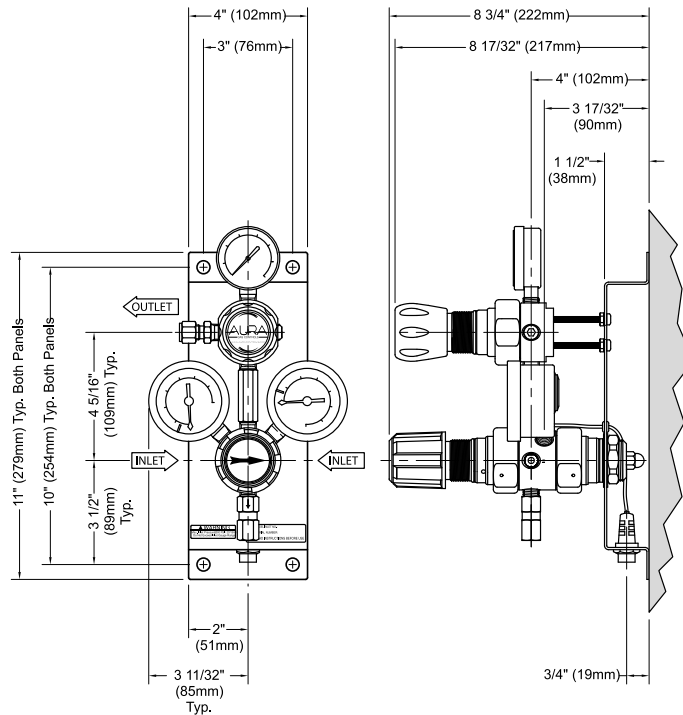

(EXDS7F00-01-000-030 shown)